

# UNIVERSAL ANTI-VIBRATION KIT (AVK) FOR MD58 MOUNTING PLATES MP000 & MPS20

## AVK ASSEMBLY

ATTACH THE OPERATOR MOUNTING BRACKET TO THE WALL BRACKET OR ANGLE AS BELOW:

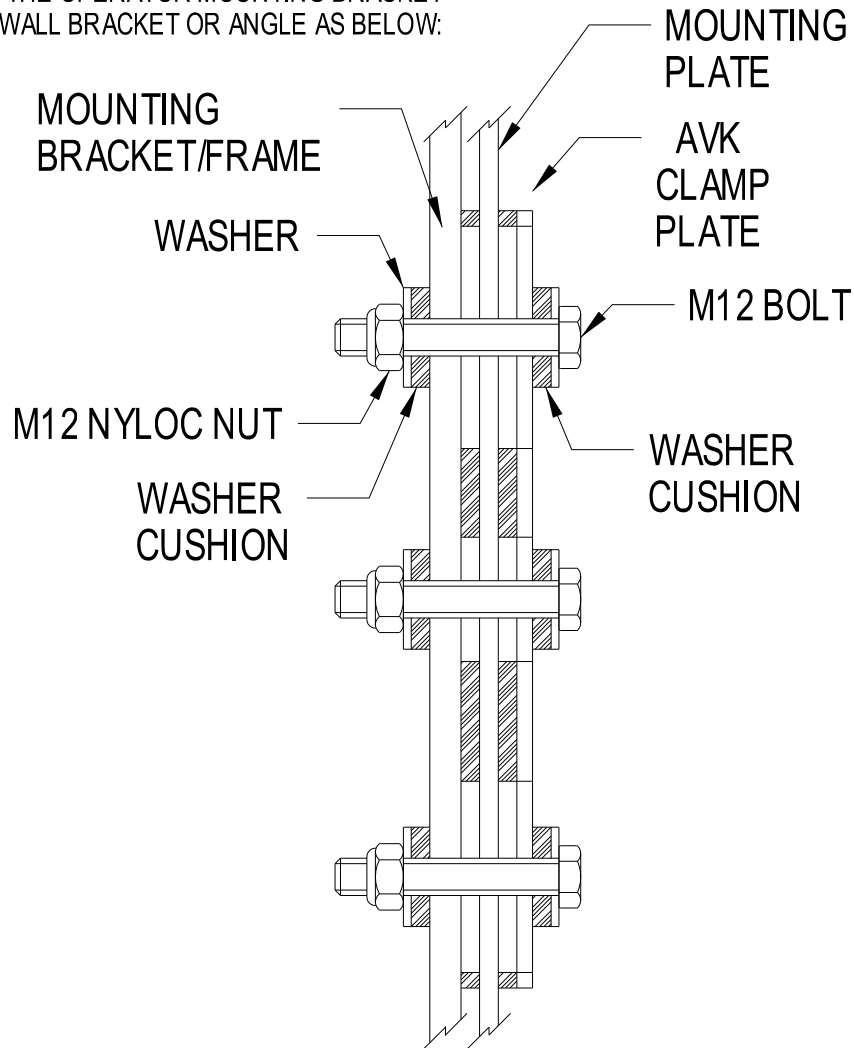

## AVK CLAMP PLATE

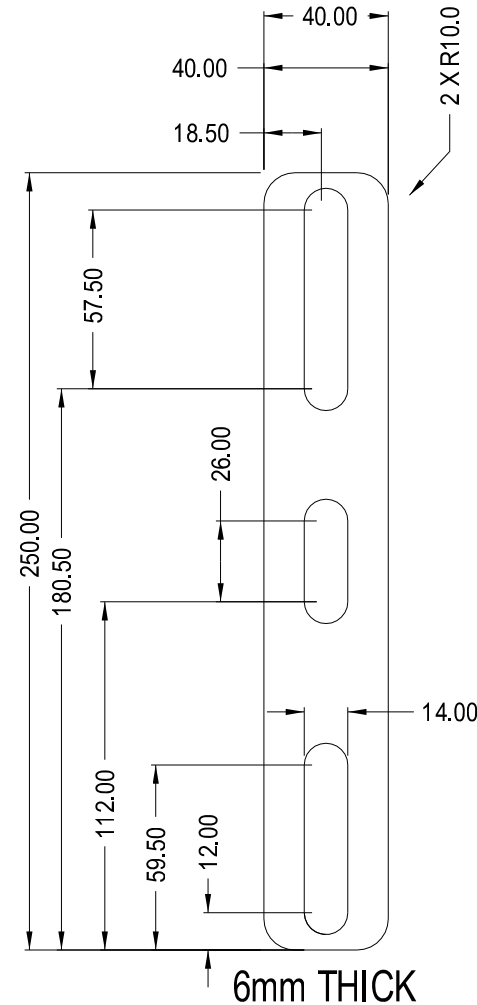

## AVK CUSHION PAD

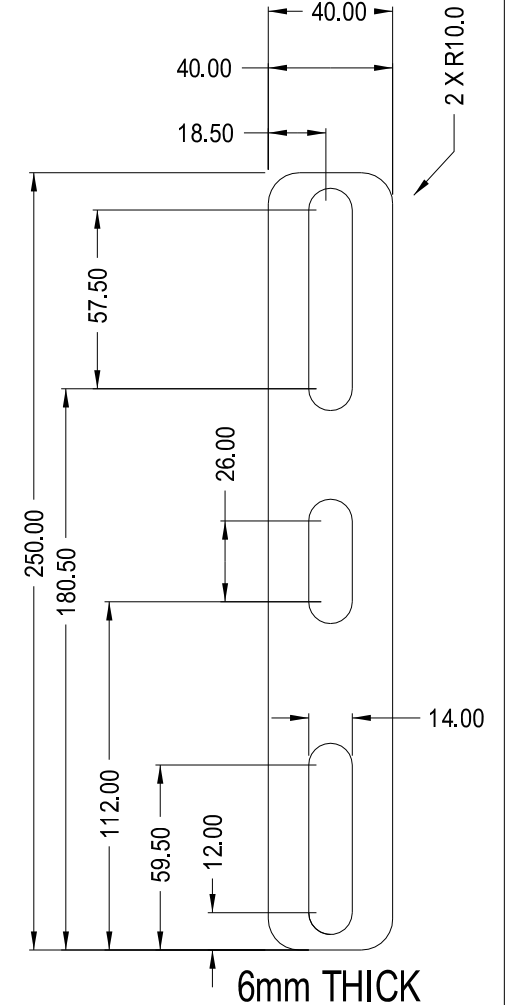

BOLTS FOR AVK HAVE RUBBER SHRINK WRAP ON THREADS SO THAT METAL TO METAL CONTACT DOES NOT OCCUR BETWEEN MOUNTING PLATE AND MOUNTING BRACKET.

AVK INCLUDES: 1x AVK CLAMP PLATE  
 2x AVK CUSHION PAD  
 6x 14x32mm WASHER  
 3x M12x60 BOLT (RUBBER COATED)  
 6x WASHER CUSHION  
 3x M12 NYLOC NUT

NOTE: MPS20 MAY NEED MODIFICATION TO SLOTS FOR APPROPRIATE FITTING